

Ethernet Transport over PDH up to 16E1/T1

XM-M16E1-4TTX

EOPDH - ETHERNET CONVERTER TO 1 - 16 E1/T1

Specifications

- Ethernet transport over 4 to 16 E1 G703 or G704
- Point to point over 16E1 or 16T1
- Or up to 16 independent links of n E1/T1, with a maximum throughput of 16E1/T1
- EoPDH using GFP with VCAT-LCAS bonding or PPP without LCP.
- Ethernet rate of n x 1980Mbps (n=1 à 16)
- Automatic reconfiguration when E1 is disappeared or is restored without interruption of Ethernet link
- Maxi delay accepted between E1 up to 217ms
- Ethernet conversion transparent to VLAN
- 4 x 10/100BaseT or
- 3 x 10/100BaseT plus 1 SFP for 100FX or
- 3 x 10/100BaseT plus 2 Combo 10/100/1000 & SFP for 1000SX or LX
- Module 4E1 RJ45
- Module 4E1 DB25 and cable to RJ45 or BNC
- Module 4E1 mini BNC
- 1 or 2 modular power supply AC or DC48 or DC24 Volt
- Local and In Band management with Telnet and SNMP with CXR-view

This equipment is used by Telco and ISP to distribute IP/Ethernet or Internet access over multiple E1/T1 links. These n E1/T1 can be transported by Microwave or SDH or PDH networks. The XM-M16E1 is a very efficient tool to deploy small DSLAM in low density area over long distance traditional Microwave. The XM-M16E1 is an automatic system bounding up to 16E1 to transport an Ethernet between two nodes or to multiple node. This Plug and Play solution provide a better bandwidth, better latency and lower cost solution than routing and bridging system.

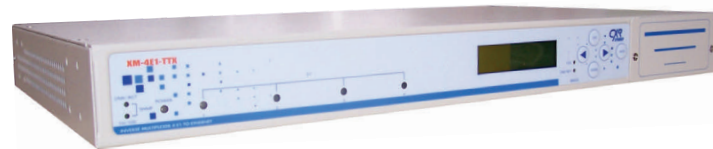

The XM-M16E1-4TTX is supporting E1 over all SDH and PDH G703 or G704 network or use Microwave links with a maximum delay of 217ms between E1 or 384ms for T1. He is concatenating the E1 in a single channel.

The XM-M16E1-4TTX is mapping Ethernet frames into a single concatenated channel.

The XM-M16E1-4TTX give the possibility to create an Ethernet link with a bandwidth up to 31,6Mbps or 16 x 1980Mbps. This equipment is using the new generation PDH technology with EoPDH using the GFP aggregation of frame, and the virtual concatenation VCAT managed by LCAS for the number of E1 available to bound and to transmit.

This technology is more effective and economic than the ML-PPP aggregation of a router. The advantages are:

- XM-M16E1 is based on Ethernet transportation at Level1 with GFP/VCAT. This mode doesn't introduce latency for very sensitive applications. *Instead the routers are using the ML-PPP transmission at Level2 and generate a fluctuant latency.*
- In case we are losing or adding an E1 link during the transmission, the LCAS of the XM-M16E1 is adjusting the bandwidth without interruption of the traffic. *In his side the ML-PPP of the router will be break, will be reconfigure and will start again with a quasi interruption of transmission when it is losing or restoring an E1 link.*

The XM-M16E1 is able to manage from 1 to 16 VC (virtual container) in case you are using for the same point to point different Microwave or PDH links or is you want to use the XM-M16E1 as a concentrator from different distant sites

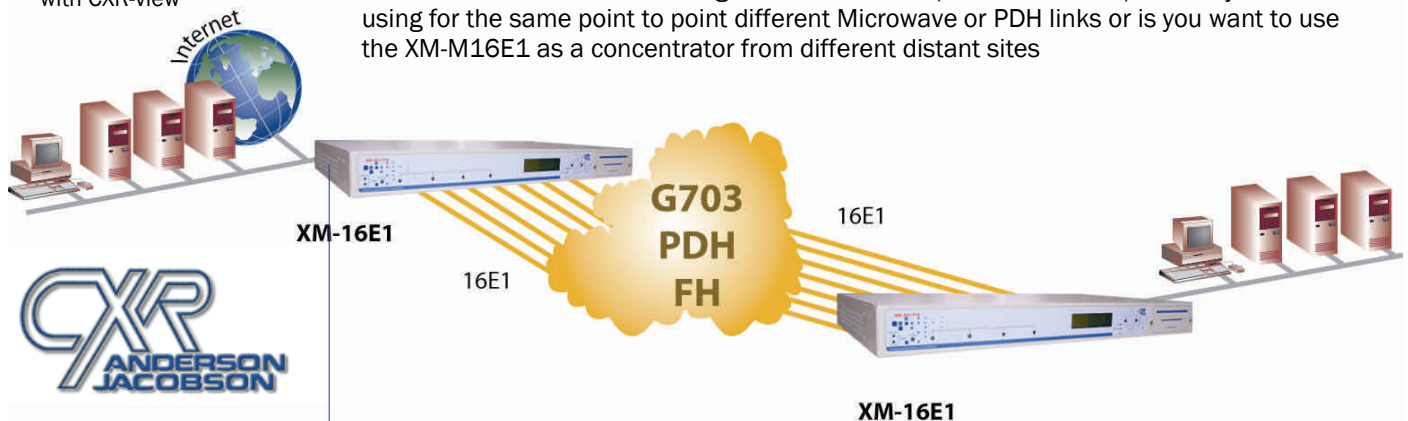



In the WAN side the **XM-M16E1-4TTX** has 4 slots for 4E1 cards .This cards can be:

- 4 E1 120 ohms with 4 RJ45 or a DB25 with cable and 4 RJ45F
- 4 E1 75 ohms with 8 mini BNC or a DB25 with cable and 8 BNC

In the LAN side the **XM-M16E1-4TTX** is delivered with 4 copper 10/100BaseT Ethernet Interfaces or 3 copper Ethernet plus one fiber Ethernet 100FX with SFP connector and soon another model with 2 combo 10/100/1000BaseT and SFP 1000SX/LX.

The Ethernet traffic can use only one Ethernet port or can be separated into the dif-

POINT TO POINT OR POINT TO MULTI-POINT INFRASTRUCTURE

ferent Ethernet ports by the selection of VCs.

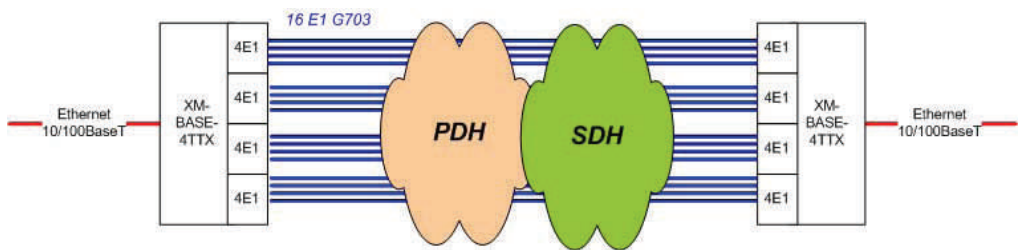

The **XM-M16E1-4TTX** can be use to provide a single Ethernet link between 2 points over 1 to 16E1.

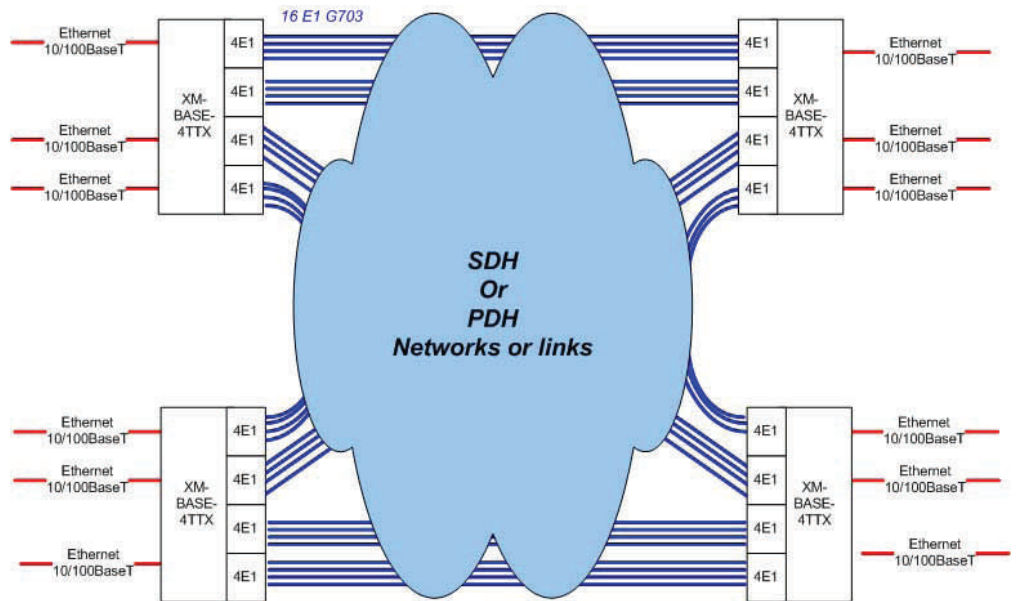

Or the **XM-M16E1-4TTX** can be use to provide point to multi-point Ethernet link between one by using 2 points over 1 to 16E1.

This feature is particularly interesting for the large infrastructures of energy production or transportation or military to reduce the number of equipments.

From a **XM-M16E1-4TTX** we can set up to 16 links (n_1 E1, n_2 E1, n_3 E1 , n_4 E1... with $n_1+n_2+n_3+n_4+....=16$).

The synchronization and bounding of each link are independent and each n_x can be different.

The information contained in this document are provided without warranty and do not constitute a contractual document. In order to improve its products, CXR reserves its right to modify, without notice, any part of this document and the specification it contains.

The **XM-M16E1-4TTX** can be used as a concentrator of 16 single Ethernet link with one E1 face to 16 CV200-TTX in HDLC.

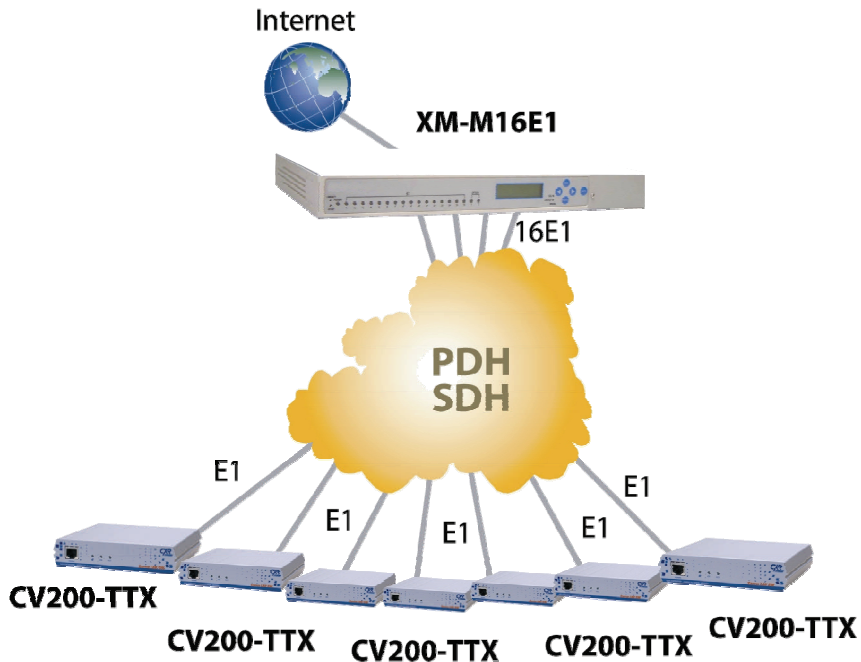

The **XM-M16E1-4TTX** can tag or double tag the incoming traffic from the Ethernet or from the E1 or T1 WAN.

This inverse multiplexer is transparent to the VLAN frame up to 12 000 bytes.

This device is used by the Telco with the double tagging, or Q-in-Q (IEEE802.1ad) feature. By using this mode the Telco can transport the customer traffic, with his own VLAN strategy, inside a VLAN of operator network.

Administration

This equipment is plug and play in case of a single link after the IP address has been set-up. The LCD and micro-PAD is giving the capability to set-up this equipment without terminal.

The administration of the XM-M16E1/T1 can be set-up locally over a consol port or an Ethernet port or over le Ethernet link.

The **XM-M16E1-4TTX** is full SNMP manageable and is provided with an SNMP MIB or it's manageable with CXR-View network management running over SNMPc.

OTHER EQUIPMENTS

The **XM-M16E1-4TTX** can be configure with the module as an inverse multiplexer 4E1/T1, 8E1/T1, 12E1/T1 or 16E1/T1. Several XM-M16E can be connected together.

The **XM-4E1-TTX** is a fixed device inverse multiplexer of 4E1 only.

Attention the XM-4E1-TTX and XM-M16E1-4TTX are not compatible together.

The **XM-M16E1-3TTX-SERIAL** is a version of the XM-M16E1-4TTX witch ones is bounding 4E1/T1, 8E1/T1, 12E1/T1 or 16E1/T1 to transport a serial interfaces from 64Kbps to 8,192Mbps as a n x 64kbps (with n=1 to 128), an RS232 asynchronous interfaces and 3 10/100Baset Ethernet up to 31,6Mbps.

This version is provide with a DCE DB9F for the RS232 and a DCE DB25F interface for the serial n 64k compatible with V35, V36/RS449, EIA530 and X21/V11 with the right cable.



TECHNICAL SPECIFICATION

Ethernet 4TTX:	4 x 10/100Baset, auto negotiation and 1x 10/100BaseT SNMP port.
Ethernet 3TTX+SFP:	3 x 10/100Baset, auto neg., 1 SNMP, 1 SFP for 100FX MM or SM.
Ethernet 3TTX+2Combo:	3 x 10/100Baset, auto neg., 1 SNMP, 2 combo 10/100/1000Baset with SFP for 1000SX or 1000LX.
Standard	IEEE 802.3u,
Connector	RJ45 auto MDI/MDIX
Administration	In Telnet, with SNMP, MIB delivered
Ethernet support	Transparent to VLAN up to 12 000 bytes VLAN tagging from Ethernet ports or E1 lines, support 802.1q VLAN double tagging (or Q-in-Q), support 802.1ad

WAN E1 interface :

Modules	4E1 , maximum 4 modules
Line	2.048 Mbps ± 50 ppm
Connector	RJ48C (120 ohm), Mini-BNC (75 ohm) or DB25 with cable
Signal	ITU G.703 and G704
Line Code	AMI et HDB3
Electrical	75 ohm et 120 ohm
Jitter	ITU G.823

WAN T1 interface :

Modules	4T1 , maximum 4 modules
Line	1,544 Mbps ± 32 ppm
Connector	RJ48C (100 ohm)
Signal	ITU G.703 and D4 or ESF
Line Code	AMI & B8ZS
Pulse template	Per AT&T TR62411

Ethernet transmission EoPDH :

Encapsulation, bounding:	GFP/VCAT with LCAC or PPP without LCP with VCAT, LAPS/HDLC
Point to Point	Transport of on Ethernet encapsulated over 1 to 16 E1 single concatenated channel
Point to Multi point:	Up to 16 Ethernet links using one VC with n E1 or T1. Throughput maximum is 16E1.
Maximum transported rate :	16 x 1980 = 31 680kbps

Clock :

Primary and secondary source: from one E1, internally or in option from an external clock.

Alarm relay:

alarm relay output for link and power monitoring

Test and diagnostic :

Test loop	Line Loopback, Payload Loopback and Local Loopback
Distant loop	Line Loopback, and Payload Loopback

Performance Monitor

E1/T1 Performance
Performance Store Last 24 hours performance in 15-minute intervals and last 7 days in 24-hour summary line, user Performance Reports Date & Time, Errored Second, Unavailable Sec., Bursty Errored Sec, Severe Errored Sec. count.
Monitor Registers User, Line
Alarm History Alarm Type(i.e. Master Clock Loss, RAI, AIS, LOS, BPV, ES, UAS)
Alarm Queue Maximum 100 alarm records which record the latest alarm type, location, and date & time
Alarm Threshold BPV, ES, UAS

Physical, Power supply :

Dimensions	432 x 44 x 255 mm (WxHxD) 1U 19" with 19" and 23" bracket
Alimentation	1 or 2 modules hot swappable module 30Watt : 100-240Vac 50/60Hz or 48Vdc or 24Vdc
Temperature	0 -50 °C
Humidity	0-95% RH (NON-CONDENSE)

ORDERING INFORMATION

XM-MBASE-4TTX

ANSI chassis with 4x10/100Baset, 1 SNMP port, 4 slots WAN, 2 slots power

XM-MBASE-3TTX-FXSM30-SC

ANSI chassis with 3x10/100Baset, 1 x100FX SM30km, 1 SNMP port, 4 slots WAN, 2 slots power

XM-MBASE-3TTX-FX-SFP

ANSI chassis with 3x10/100Baset, 1 x100FX SFP, 1 SNMP port, 4 slots WAN, 2 slots power

XM-MBASE-3TTX-2Combo

ANSI chassis with 3x10/100Baset, 2 Combo 10/100/1000Baset & SFP Giga, 1 SNMP port, 4 slots WAN, 2 slots power

Modules

XM-MMOD-4E1-RJ45

Module 4 E1 120 ohms, 4 RJ45, for XM-BASE-4TTX, 4 maxi

XM-MMOD-4E1-DB25

Module 4 E1 120 ohms, 1 DB25, for XM-BASE-4TTX, 4 maxi

XM-MMOD-4E1-MBNC-75

Module 4 E1 75 ohms, 8 mini BNC, for XM-BASE-4TTX, 4 maxi

XM-MMOD-4E1-DB25-75

Module 4 E1 75 ohms, 1 DB25, for XM-BASE-4TTX, 4 maxi

CA-XM-DB25-4RJ45M

3m cable for module XM-MOD-4E1-DB25

CA-XM-DB25-8BNC

3m cable for module XM-MOD-4E1-DB25-75

XM-MMOD-AC

Power supply 110V/230V for XM-BASE-SW4TTX (maxi 2)

XM-MMOD-DC24

Power supply 24Vdc for XM-BASE-SW4TTX (maxi 2)

XM-MMOD-DC48

Power supply 48Vdc for XM-BASE-SW4TTX (maxi 2)

